



GENERAL-PURPOSE CNC PRESS BRAKE 40032

The information reserves the right to be modified without prior notice.

GENERAL-PURPOSE CNC PRESS BRAKE

- Modern minimalist industrial design, attractive and elegant appearance
- Optimized parameter matching and high-quality core components, ensuring stable performance and ease of operation
- High-rigidity frame with automatic mechanical deflection compensation for precision bending
- Advanced assembly processes and rigorous standards, ensuring stable, full-process quality control
- Professional and complete after-sales service system:
 - Regional management of sales and after-sales personnel
 - Fast response mechanism for timely customer support
 - Customized products and services available upon request
 - Full-set automated sheet metal solutions offered

MAIN MACHINE PARAMETERS
MODEL:PPB 400X3200 (N+V) TECHNICAL SPECIFICATIONS

Name	Unit	PPB 400x3200
CNC		Delem system Y1, Y2, X, R, Z1 Z2 axes
Crowning system		Mechanical Crowning
Max bending force	T	2x400
Max bending length	mm	2x3200
Y-axis motor power	KW	2x30
X/R-axis motor power	KW	2x1/1
Z-axis motor power	KW	2x0.4
Total Installed Power	KVA	2x41
Distance between columns	mm	2700
Throat depth	mm	500
Daylight	mm	680
Machine Weight	kg	2x23500
Oil tank capacity	L	2x450

MAIN MACHINE PARAMETERS

MODEL:PPB 400X3200 (N+V) TECHNICAL SPECIFICATIONS

Name		Unit	PPB 400x3200
Top tool			Penta
Bottom tool			Penta
Travel	Cylinder stroke	mm	315
	X-axis	mm	500
	R-axis	mm	200
	Z-axis	mm	2100
Y axis downward speed		mm/s	100
Y-axis forward speed		mm/s	8
Y-axis return speed		mm/s	85
X-axis forward speed		mm/s	400
R-axis forward speed		mm/s	200
Z-axis forward speed		mm/s	1600

MAIN MACHINE PARAMETERS

MODEL:PPB 400X3200 (N+V) TECHNICAL SPECIFICATIONS

Name		Unit	PPB 400x3200
Positioning Accuracy	Y-axis repeat	mm	±0.01
	X-axis	mm	±0.1
	R-axis	mm	±0.1
	Z-axis	mm	±0.1
	V-axis	mm	±0.02
Dimension	Length	mm	2x3890
	Width	mm	2200
	Height	mm	3310

Note: N is the number of axes, including Y1, Y2, X, R, etc.; V is the compensation axis (Mechanical crowning)

PPB 400T CONFIGURATION LIST

No	Name	Type	Brand
1	CNC	6+1 axis DA66S	DELEM
2	Back gauge servo motor+ Z axis motor	EM3G-09+EM3A-04	ESTUN
3	Hydraulic system main valve	Electro-hydraulic servo hydraulic valve group	
		Synchronous control assembly	a. Back pressure-valve
			b. Poppet valve
			c. Proportional servo valve
		Hydraulic control assembly	a. Cartridge valve
			b. Pressure sensor
c. Directional valve			
d. Proportional pressure reducing valve			
4	Linear guides	35	SHAC
		25	SHAC

PPB 400T CONFIGURATION LIST (CONT.)

No	Name		Brand
5	Ball screws	880/1000	SHAC
6	Oil pumps	LXPG1H-50	Bosch-Rexroth
7	Full set of cylinder seals	Fully sealed	PARKER or SKF
8	High-pressure hydraulic pipes	1. GE16 ZSR 3/4EDCF	PARKER/ BRENNAN
		2. GE28 LR3/4EDOMDCF	
		3. W10 ZLCF	
		4. WH10 ZSR KDSCF	
		5. WH10 ZLR KDSCF etc	
9	Coupling	GGRMP	SIT
10	AC contactor/ button	LC1D, XB2B, OSM	Schneider
11	Foot switch	FLS-XP-M62	Ruike
12	Main servo motor	Induction Motor Y200L-4(30KW)	Siemens Beide
13	Magnetic scale	MPS/GVS315LC	OPKON/ELGO
14	Compensation system	PT-100x95mm	Dazhong/Shuheng
15	Safety Fence	FPBS	ESTUN

MACHINE PERFORMANCE AND STRUCTURAL FEATURES

3.1 MACHINE DESIGN AND COMPONENTS

- The machine frame design is optimized by utilising finite element process to ensure high strength and rigidity.
- The main motor is a Siemens Beide induction motor, with high power ensuring stable bending tonnage.
- The German Rexroth fully closed-loop electro-hydraulic servo synchronous control system, and the fast response of the high-frequency valve group ensures that the machine has high stability and high precision during high-speed operation.
- The optimized combination daylight, throat depth, back gauge stroke enables you to perform larger and more complex workpieces without any additional costs.

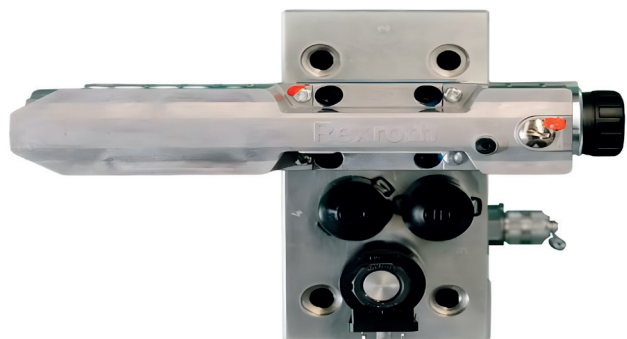
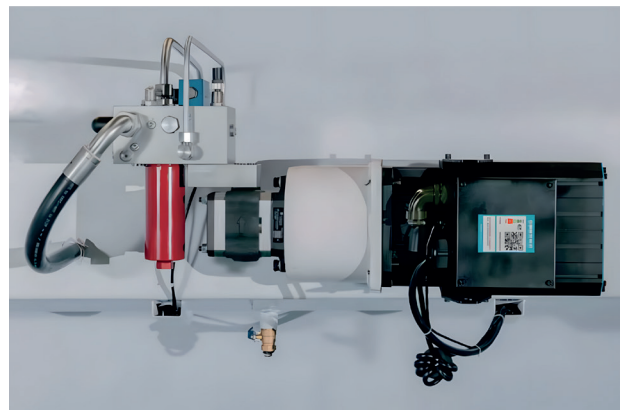
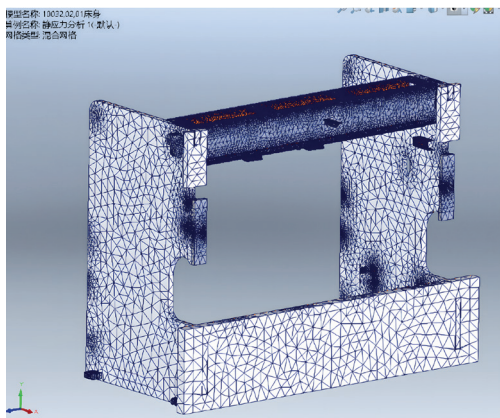

MACHINE PERFORMANCE AND STRUCTURAL FEATURES (CONT)

3.2 FRAME BODY

- Fully welded steel structure with excellent vibration resistance.
- The frame is stress relieved via a vibration process which ensures greater frame stability and resistance to deformation.
- Frame is machined on a 5-axis machining center, this guarantees parallelism and perpendicularity of mounting surfaces.
- The throat of the machine frame is equipped with a C-frame mechanism to ensure bending accuracy and stability.

3.3. HYDRAULIC SYSTEM

- Hydraulic connectors are from PARKER/SKF or BRENNAN(USA), which ensures a long service life;
- Including the most advanced full closed-loop electro-hydraulic servo synchronous control system;
- The machine can work on a continuous basis related to the specified parameters, and the hydraulic system ensures a leak-free and stable processing experience with high precision.



MACHINE PERFORMANCE AND STRUCTURAL FEATURES (CONT)

3.4 BACK GAUGE SYSTEM

- The Z axis has a high positioning accuracy with fine tuning functionality for ease operation and high accuracy;
- The X and R axes are equipped with ball screws linear guide rails drive system, which are equipped with digital AC servo motors, with retract control function.
- The Z-axis provides low noise operation and high speed performance.

3.5 ELECTRICAL SYSTEM

- Electrical components are from international or joint-venture brands, in line with international standards, and the electrical control cabinet is equipped with refrigeration unit.
- Analog cables are equipped with shielded cable to avoid electrical interference.
- The enclosure of the electronic control cabinet meets the national standard IP54 protection standard.
- The double foot pedal switch enables up and down movements for convenient and simple operations.

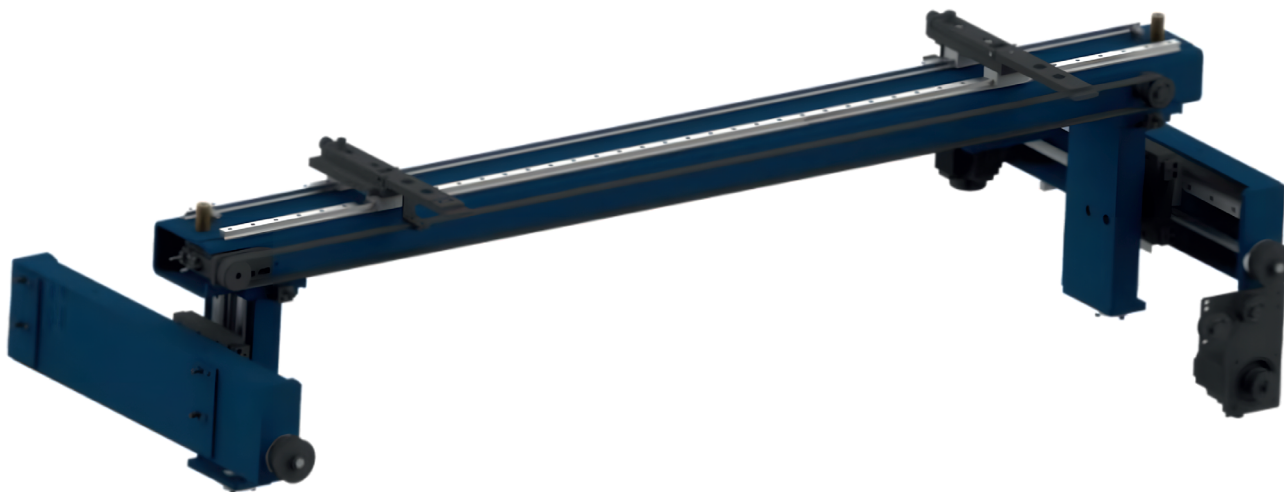

(6+1)

MACHINE PERFORMANCE AND STRUCTURAL FEATURES (CONT)

3.6 MECHANICAL CROWNING

- The design center slot and flat plate of the mechanical compensation worktable are universal;
- The structure with dense point wedge compensation meets the angular accuracy requirements of the full bending length of the workpiece.
- Integrated speed reduction motor and scale.
- The closed-loop control of compensation has high control accuracy, and the compensation value is automatically calculated and set by the CNC to ensure a consistent bending angle over the total length.



MACHINE PERFORMANCE AND STRUCTURAL FEATURES (CONT)

3.7 CONTROL SYSTEM - DELEM DA66S SYSTEM OF THE NETHERLANDS

- Adoption of a real-time Linux embedded OS allows for instant shutdown.
- Multiple language options, including Chinese interface, ensure user-friendly operation.
- Fashionable exterior design and easy operation reflect a user-oriented approach.
- Intelligent modular structure supports flexible expansion up to 24 axes.
- High-brightness 24-inch TFT color LCD display with 4G memory capacity.
- Built-in programmable PLC ensures stability and reliability, reducing hardware wiring through logical programming.
- Standard USB port, flash drive, network interface, and RS232 communication interface.
- Automatic accumulation of machine working hours and bending cycles.
- Product annotation/editing, marking functions, and calculator capabilities.
- Fully touch-enabled digital and 2D/3D graphical programming, with automatic bending process planning and simulation.
- Machine outline, tools, and workpieces can be scaled freely in a 1:1:1 graphical representation.
- Digital and graphical tool programming for flattening tools, large-radius tools, multi-V tools, and adjustable V-tools.
- Automatic angle correction database, self-learning bending tolerance table, and comprehensive collision detection.
- Error warning system to prevent incorrect operations.
- Built-in production management software for productivity statistics.
- Remote and on-site diagnostic functions, enabling monitoring of I/O digital signals, analog signals, and axis status.
- Dedicated machine analysis software for real-time monitoring.



SUPPLIED DOCUMENTATION AND ACCESSORIES

Item	Quantity	Remark
CNC system instruction manual	1	
Machine operate manual	1	
Electrical schematic diagram	1	
User precision adjustment manual	1	Electronic version
Standard Mold	1	

CUSTOMER RESPONSIBILITY

1. Hydraulic Oil:

high quality 46# anti-wear hydraulic oil.

2. Power Supply:

380V,50HZ, voltage fluctuation is $\pm 5\%$

3. Ambient Temperature:

0°C- +40°C

4. Environmental Humidity:

20-80%RH

5. Environment

with less dust and no harmful or corrosive gases