

FIBER LASER CUTTING MACHINE SWING VII PRO LITE

WHAT MAKES THE SWING VII PRO LITE DIFFERENT

The Penta SWING VII PRO Lite is built on the same industrial-grade chassis, structure, and control architecture as the flagship SWING VII PRO. It features the identical Smart Manager operating system, Z32 Italian CNC control, Smart Nesting software, and Maxphotonics power source—ensuring precision, repeatability, and long-term reliability.

Where it differs is in component sourcing:

The Lite model integrates Chinese-manufactured subcomponents, including the cutting head and selected motion control parts, all of which have been extensively proven in Penta's domestic high-volume production fleet. These components are designed and validated to meet Penta's internal quality benchmarks while significantly enhancing cost efficiency—delivering premium performance without the premium price tag.

ENGINEERED FROM EXPERIENCE. BUILT FOR EFFICIENCY.

With thousands of machines operating in China and globally, Penta Laser leverages its field data and R&D ecosystem to continuously optimize designs for durability, uptime, and throughput. As a true manufacturer—not a system integrator—**Penta controls every stage of development, from optical design to assembly and software. This vertical integration ensures synergy between European-grade engineering and Chinese cost-effective manufacturing, creating a value proposition unmatched in the fiber laser industry.

A STRATEGIC ALLIANCE FOR THE FUTURE.

In 2025, Penta Laser currently the world leaders in high power Laser cutting machines entered a new chapter through its partnership with YOFC (Yangtze Optical Fibre and Cable)—a global leader in optical fibre preforms, cables, and integrated photonic solutions, with a market capitalization exceeding USD 1.6 billion (2024). This partnership amplifies Penta's manufacturing capacity, R&D depth, and global scalability, reinforcing its leadership in ultra-high-power laser cutting and setting the stage for the next era of smart manufacturing

SWING VII Pro Lite 3015 High-power laser cutting machine is mainly used for the processing of carbon steel, stainless steel, aluminum alloy, brass, red copper, pickled plate, galvanized plate, silicon steel plate, electrolytic plate, titanium alloy, manganese alloy and other plates with a length of not more than 3 meters and

a width of not more than 1.5 meters, advantages in cutting medium to thin plates

CUTTING SAMPLES

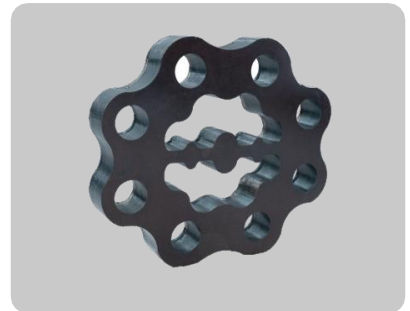

MAIN TECHNICAL PARAMETERS

Technical parameter	
Model	SWING VII Pro Lite 3015
Power	6000W/12000W
X-axis travel	3000mm
Y axis travel	1500mm

Accuracy of positioning of axis X/Y (GB/T 17421.2-2023)	± 0.03mm
Repeatability of positioning of axis X/Y (GB/T 17421.2-2023)	± 0.01mm
Rapid speed	140m/min
Maximum Acceleration	1.5G

MAIN CONFIGURATION

Serial number	Main components	Brand
1	Laser source	MAXPHOTINCS
2	Cutting head	EC+Ophit
3	Z32 CNC system (including control software)	ELEN Group
4	X/Y/W axis rack	STR RONSE
5	Guide rail	SMS
6	Reducer	DESBOER
7	AC servo motor	INOVANCE
8	Proportional control valve	Lanny
9	Laser cutting process database	ELEN Group
10	Nesting software	Lantek

11	Chiller	DVT
12	Dust collector	TOPSIN
13	Air compressor	Local

Note:

If the customer purchases the above devices themselves, they must purchase the specified brand and model. If the brand is changed

arbitrarily, the customer is responsible for any impact on the overall performance of the machine.

The warranty period for Standard Auxiliary Systems provided by us is 1 year.

The connection of the air compressor should be installed by the customer themselves

SWING VII PRO LITE 3015 STEEL CUTTING MACHINE

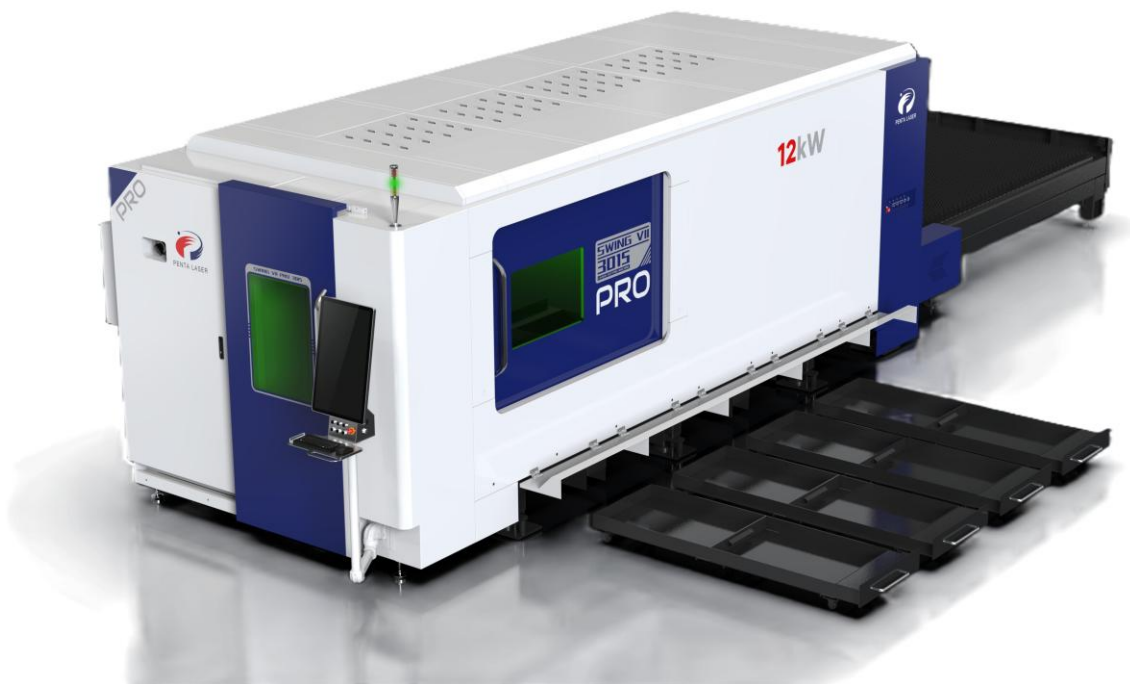

(The picture is for reference only; the appearance and size are subject to the actual factory equipment.)

LASER CUTTING HEAD

EC+Ophit intelligent laser cutting heads are mainly used in industrial laser production and processing industries. It has an automatic focusing function, built-in water cooling, a reasonable optical system, and 2 sets of upper and lower protective lenses to effectively isolate impurities and dust. It can accurately adjust the focus automatically, and the heat dissipation effect and continuous working time are obviously improved, and it can meet the cutting of thin and medium-thick plates in different processing environments.



Project name	Technical parameters	Project name	Technical parameters
Cutting materials	MS,SS,AL,Brass, Copper etc	Auxiliary gas input	O2, AIR, N2
Cutting head	Capacitive height adjuster	Auxiliary gas output	CNC select gas type

INTRODUCTION TO EQUIPMENT CONFIGURATION

The base is mainly composed of integral base, gantry beam, sliding seat, Z-axis, floor-type worktable, cooling system, pneumatic system, dross collecting system, dust removal system and other components.

MACHINE BASE

The base is an integral hollow structure, which is formed by tube-plate structure and is finished after secondary accurate treatment, with good strength and high precision. The lower part of the machine body is equipped with partitioned dust removing system and a drawer-type slag removal trolley; the cutting area is paved with anti-burning materials to protect the machine tool from deformation.



BEAM

The cross beam is of a gantry-moving type structure and is a honeycomb type welding steel beam with lightweight design, and is formed by secondary aging treatment and finish machining after being welded and formed, so that the beam has good strength and high precision; a high-precision rolling linear guide rail and a helical rack are configured on the cross beam, and a fire-resistant full-sealed dust cover is used for protection, so that the stability and the service life of the transmission structure are improved; At the same time, both sides of the gantry are equipped with high torque servo motor and high rigidity flange reducer drive, which has good synchronization and high dynamic performance.

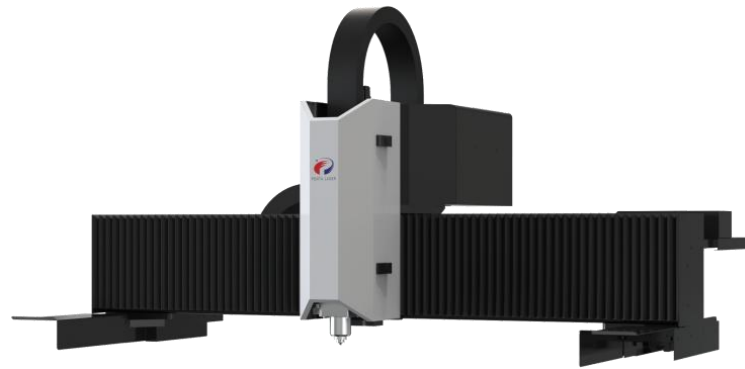

WORKING TABLE

The worktable is a separate floor-type structure with good strength and high bearing capacity. The cutting area adopts a unique detachable grille design and is equipped with heightened and thickened toothed plates, which have good strength and long service life; the spacing of the toothed plates and the design of the fillets are more humanized, which can not only ensure the stability of the structure, but also make it safer. Graphite protective material is installed at the connecting beam of the worktable to ensure that the worktable will not collapse after cutting for a long time.



DUST REMOVAL SYSTEM

With the unique design of zonal blowing-pumping dedusting system, when the cutting head works in a certain area, the dust-pumping air door of the corresponding area will automatically open. The design of zonal dust removal is integrated in the machine tool, under the worktable, which can ensure good dust removal effect. Professional dust remover can be selected to remove dust, like waste gas and other substances in the production process, and after filtration and emission treatment, the working environment can achieve a comfortable effect.

PNEUMATIC SYSTEM

Pneumatic system is divided into auxiliary cutting system and auxiliary control system. The auxiliary cutting system consists of three paths of gas, namely N₂, O₂ and Air, and can automatically select the gas and automatically adjust the air pressure according to the cutting material; and meanwhile, each gas path is provided with a pressure adjustment detection switch to prevent the cutting head and the optical fiber from being damaged due to continuous light emission when the gas is insufficient, so that the auxiliary cutting system is safe and reliable. The auxiliary control system mainly controls the action of the dust removal air door. The main components of the gas circuit are imported or specially customized to ensure that the machine tool has the highest cutting performance and stable use qualitative.

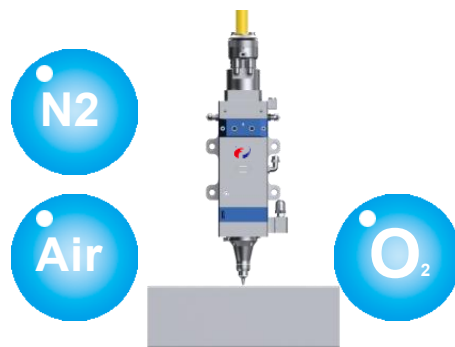

LASER

Laser With professional fiber laser, it has the following characteristics:

- The electro-optical conversion efficiency is up to 35% -40%, which greatly reduces the use cost.
- High stability greatly reduces the requirements for laser quality monitoring in operation.
- Long life, high precision, maintenance-free.
- In industrial applications, it is much superior to traditional lasers, which shows that it has the best

wavelength and the best beam quality for metal processing.

- The semiconductor optical fiber is used as a laser generation medium, so that the laser generation gas is not needed, the method is environment-friendly, and the cost is low.



CNC SYSTEM

THE CONTROL SYSTEM IS ITALIAN Z32 BUS TYPE NUMERICAL CONTROL SYSTEM.

- New Z32 real time CNC system, with dynamic and geometric JERK control.
- The data exchange between CNC system and machine drive system is adopted with bus.
- 27" TFT with LCD.
- USB port, ethernet interface, can achieve remote assistance.
- Power modulation for the ultimate cutting quality in the corners.
- Z axis following to eliminate the influence of uneven plate.
- Automatically choosing gas type and pressure (N₂, O₂ and Air).
- Auto restart procedure.

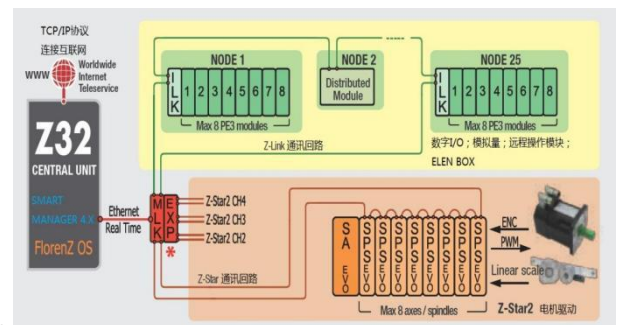

OPERATING SYSTEM SMART MANAGER

Smart Manager is originally imported from Europe. This software is based on the Windows 10 system and can fully interface with Italy CNC system which original imported also. Therefore the real control of the machine, the laser source and software update is more convenient and fast

- Friendly interface, easy to learn and operation; easy to edit the numerical control program and high readability.
- Cutting parameters database is available, at the same time the real time adjustment to the cutting quality.
- Optimize various fast moving modes, have the function of frog jump and turn off the assisting gas automatically when fast moving.
- Easier and faster in automatic edge-finding function

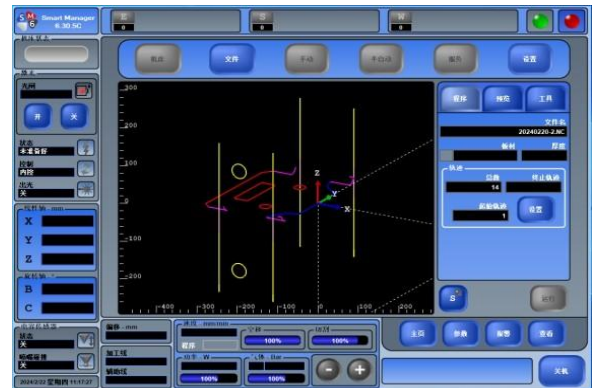

PROFESSIONAL NESTING SOFTWARE

SWING VII NC laser cutting machine is configured with the Spanish Lantek automatic nesting software for professional laser cutting, which has powerful functions such as automatic programming, nesting, layout, word processing, and process setting, and maximizes the management and utilization rate of sheet metal. Lantek nesting software has the following functions and features:

- Based on AUTO CAD/CAM automatic program nesting software and easy to use.
- Multilayer nesting functions to intensively increase the sheet usage rate
- Use divisional cutting path to avoid over heat.
- Parameter setting: automatically apply different cutting parameters to different materials and thickness based on customer's requirement.
- Edge-sharing cutting function optimizes the cutting efficiency and increase the sheet usage rate.
- Pre-perforation: Accomplish the pre-perforation as settled.
- Make use of the rest materials

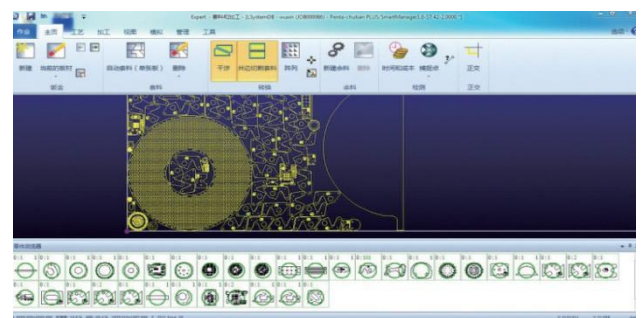

INOVANCE AC SERVO MOTOR AND DRIVE WITH DESBOER REDUCER

The machine tool adopts INOVANCE bus-type servo motor and drive, which has good precision, good dynamic performance and fast response, and ensures the machine tool to run stably with high precision. \

